

MAILFORCE 3 FIXED DEPTH CHUTE



The Mailforce 3 Fixed Depth mail chute is designed for secure through-the-wall mail storage. Typically installed in an external property wall, it features an aperture on one side for mail posting and a locked door on the opposite side, accessible only with a coded key.

This model is better suited for properties with limited wall depth compared to the Mailforce 1 and 2 models. The Mailforce 3 can be customised with one colour on the front face and a different colour on the rear door, ensuring it meets the design specifications of any project.

DIMENSIONS

APERTURE SIZE (MM): 18H X 350W

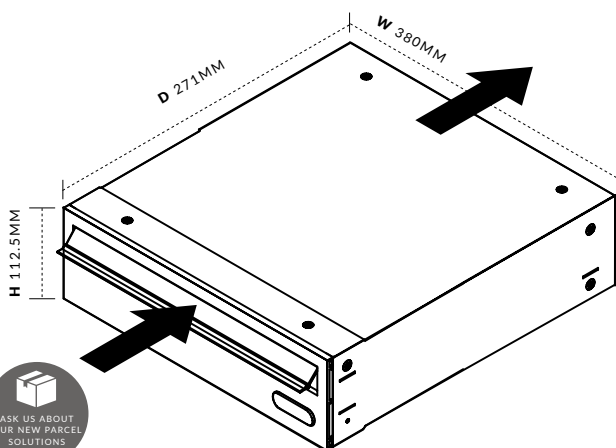

MAILBOX FEATURES:

Overview

- Dimensions (mm): 112.5H x 380W x 271D
- Aperture Size (mm): 18H x 350W
- Will accept A4 Mail

Finishes

- Zintec Steel body and Aluminium Extrusion front face
- Polyester powder coating paint
- Available in all standard RAL colours as standard
- Option to upgrade to any RAL colour for an additional fee
- Weather and vandal resistant

Installation Options

- Bankable up to 10 high, no restriction on width
- Through the Wall
- Integrates with Door Entry Systems
- Bespoke Arrangement

Applications

- Suitable for internal or external use

Compliance

- Conforms to Secured by Design Homes 2024 guidelines

Accessories/Optional Extra

- Can be engraved or fitted with Vinyl lettering
- Aperture restrictors