

# MAILFORCE 3 TELESCOPIC DEPTH CHUTE



The Mailforce 3 Telescopic Depth mail chute is designed for secure through-the-wall mail storage. Typically installed in an external property wall, it features an aperture on one side for posting mail and a locked door on the other side, accessible only with a coded key.

The telescopic version of the Mailforce 3 is suitable for developments with external property walls of varying depths, accommodating dimensions between 271mm and 420mm when the exact wall depth is unknown.

## DIMENSIONS

APERTURE SIZE (MM): 18H X 350W

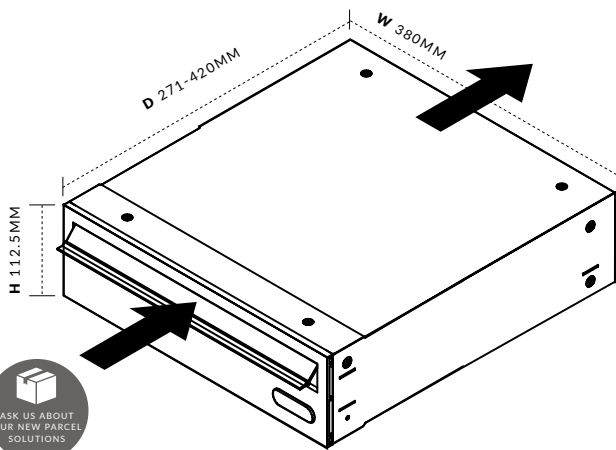

## MAILBOX FEATURES:

### Overview

- Dimensions (mm): 112.5H x 380W x 271 - 420D
- Aperture Size (mm): 18H x 350W
- Will accept A4 Mail

### Finishes

- Zintec Steel body and Aluminium Extrusion front face
- Polyester powder coating paint
- Available in all standard RAL colours as standard
- Option to upgrade to any RAL colour for an additional fee
- Weather and vandal resistant

### Installation Options

- Bankable up to 10 high, no restriction on width
- Through the Wall
- Integrates with Door Entry Systems
- Bespoke Arrangement

### Applications

- Suitable for internal or external use

### Compliance

- Conforms to Secured by Design Homes 2024 guidelines

### Accessories/Optional Extra

- Can be engraved or fitted with Vinyl lettering
- Aperture restrictors