

COM 1 EXTRA HEAVY DUTY MAILBOX

DATASHEET

One Cartwright Gardens

The COM 1 extra heavy duty mailbox is a variation of the classic COM 1 mailbox incorporating strengthened materials, along with a range of additional security features.

The extra heavy duty version of the COM 1 mailbox is fitted with a gap restricting aperture as standard, an anti-leverage surrounding trim, retrieval door that uses a welded claw that negates the ability to gain a leverage point and compromise the security of the mailbox, and a 3-point locking mechanism that enhance the locking security of the product.

DIMENSIONS

APERTURE SIZE (MM): 13H X 229W

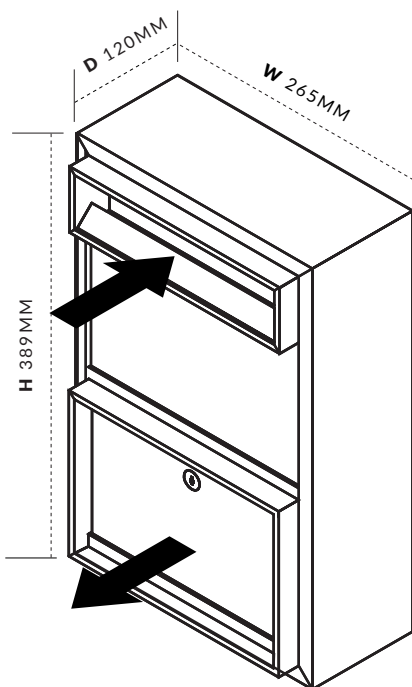

MAILBOX FEATURES:

Overview

- Dimensions (mm): 389H x 265W x 120D
- Aperture Size (mm): 13H x 229W
- Can securely store A4 Mail
- Fitted with a 3 point locking mechanism for ultimate security

Finishes

- Strengthened Zintec Steel & Aluminium Extrusion
- Polyester powder coating paint
- Available in all standard RAL colours as standard
- Option to upgrade to any RAL colour for an additional fee

Installation Options

- Bankable up to 4 high, no restrictions on width
- Can also be used as a single box
- Freestanding – on support legs
- Recessed or Wall Mounted
- Bespoke Arrangement

Applications

- Suitable for internal and external use

Compliance

- BS EN13724 Compliant
- Conforms to Secured by Design Homes 2025 guidelines

Accessories/Optional Extra

- Can be engraved or fitted with Vinyl lettering
- A variety of colour strips available

