

# COM 3 MAILBOX DATASHEET

Door Entry System Project

The COM 3 mailbox is a front-loading, rear-retrieval unit typically installed outside a property for convenient indoor mail collection. It can accommodate up to 10 mailboxes in a single vertical column, making it an efficient solution for maximising space.

The COM 3 can also be integrated with door entry systems, either as part of a complete solution or with customised panels that feature openings to house access units.

It is available in any colour from our standard RAL range.

## DIMENSIONS

APERTURE SIZE (MM): 26H X 235W

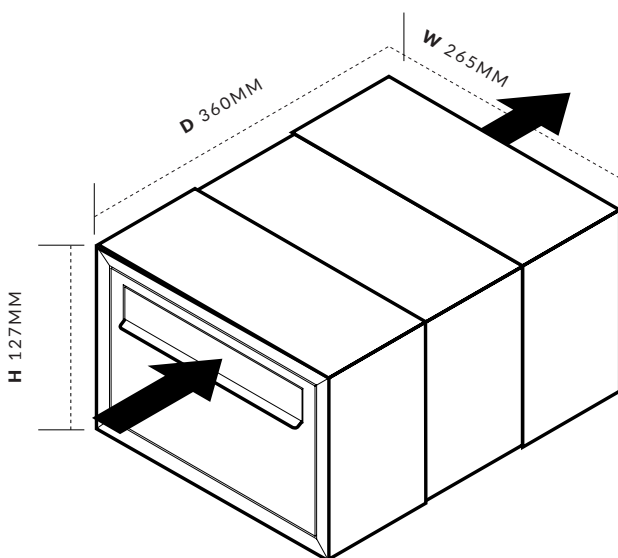

## MAILBOX FEATURES:

### Overview

- Dimensions (mm): 127H x 265W x 360D
- Aperture Size (mm): 26H x 235W
- All models can securely store A4 Mail

### Finishes

- Aluminium Extrusion & Zintec Steel
- Polyester powder coating paint
- Available in all standard RAL colours as standard
- Option to upgrade to any RAL colour for an additional fee

### Installation Options

- Bankable up to 10 high, no restrictions on width
- Can also be used as a single box
- Through the Wall
- Compatible with Door Entry System
- Bespoke Arrangement

### Applications

- Suitable for internal and external use

### Compliance

- BS EN13724 Compliant
- Conforms to Secured by Design Homes 2025 guidelines
- Meets Class 0 (BS 476: Parts 6 & 7)

### Accessories/Optional Extra

- Can be engraved or fitted with Vinyl lettering
- A variety of colour strips available

