

GUARDIAN REAR RETRIEVAL (RR) MAILBOX DATASHEET

Design to Installation



The Guardian RR box is an in-front, out-back solution designed to securely store mail in the top compartment while also functioning as a storage box in the bottom compartment. This design includes both locked and unlocked compartments, making it ideal for installation in external property walls.

The top section features a mail slot and is fitted with an SLB security lock, ensuring that mail remains securely stored until accessed with a coded key. The lower compartment is well-suited for holding items like milk, bread, and newspapers, allowing for convenient retrieval later on.

DIMENSIONS

APERTURE SIZE (MM): 26H X 235W

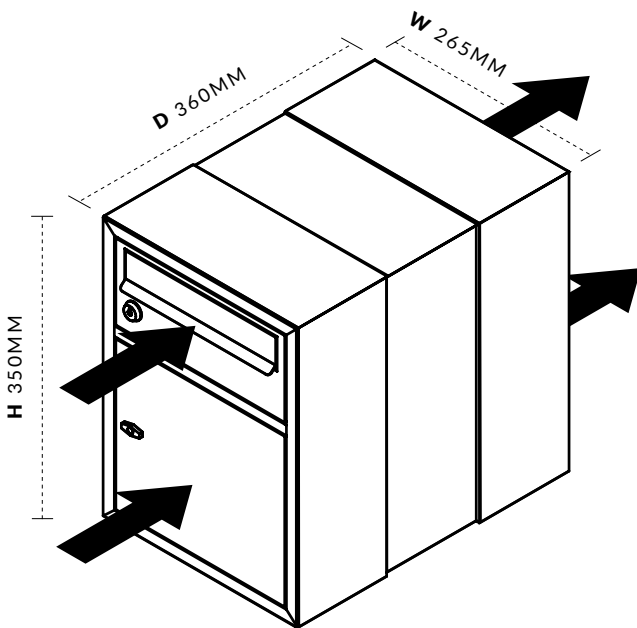

MAILBOX FEATURES:

Overview

- Dimensions (mm): 350H x 265W x 360D
- Aperture Size (mm): 26H x 235W
- Will accept A4 Mail

Finishes

- Zintec Steel
- Polyester powder coating paint
- Available in all standard RAL colours as standard
- Option to upgrade to any RAL colour for an additional fee

Installation Options

- Bankable up to 3 high, no restriction on width
- Through the Wall
- Integrates with Door Entry Systems
- Bespoke Arrangement

Applications

- Suitable for installation into external property walls

Compliance

- BS EN13724 Compliant
- Meets Class 0 (BS476: Part 6&7)
- Conforms to Secured by Design Homes 2025 guidelines

Accessories/Optional Extra

- Can be engraved or fitted with Vinyl lettering

