

# MAILFORCE 1

## FIXED DEPTH CHUTE

### DATASHEET

Design to Installation



The Mailforce 1 Fixed Depth mail chute is designed for secure through-the-wall mail storage.

It is typically installed in an external property wall, with an aperture on one side for mail to be posted through and a locked door on the other side that can only be accessed with a coded key.

The Mailforce 1 can be customised with a different colour on the front face and the rear door, allowing it to meet the specific design requirements of any project.

#### DIMENSIONS

APERTURE SIZE (MM): 18H X 230W

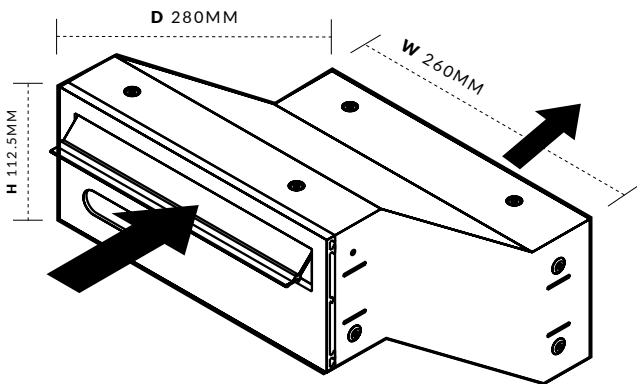

## MAILBOX FEATURES:

### Overview

- Dimensions (mm): 112.5H x 260W x 280D
- Aperture Size (mm): 18H x 230W
- Will accept A4 Mail

### Finishes

- Zintec Steel body and Aluminium Extrusion front face
- Polyester powder coating paint
- Available in all standard RAL colours as standard
- Option to upgrade to any RAL colour for an additional fee
- Weather and vandal resistant

### Installation Options

- Bankable up to 10 high, no restriction on width
- Through the Wall
- Integrates with Door Entry Systems
- Bespoke Arrangement

### Applications

- Suitable for internal or external use

### Compliance

- Conforms to Secured by Design Homes 2025 guidelines

### Accessories/Optional Extra

- Can be engraved or fitted with Vinyl lettering
- Aperture restrictors

