

MAILFORCE 2

TELESCOPIC DEPTH CHUTE

DATASHEET



The Mailforce 2 Telescopic depth mail chute is designed for secure through-the-wall mail storage. Typically installed in an external property wall, it features an aperture on one side for posting mail and a locked door on the other, accessible only with a coded key.

The telescopic version of the Mailforce 2 is ideal for developments with variable external wall depths or when the exact depth is unknown, accommodating dimensions between 270mm and 420mm.

DIMENSIONS

APERTURE SIZE (MM): 18H X 230W

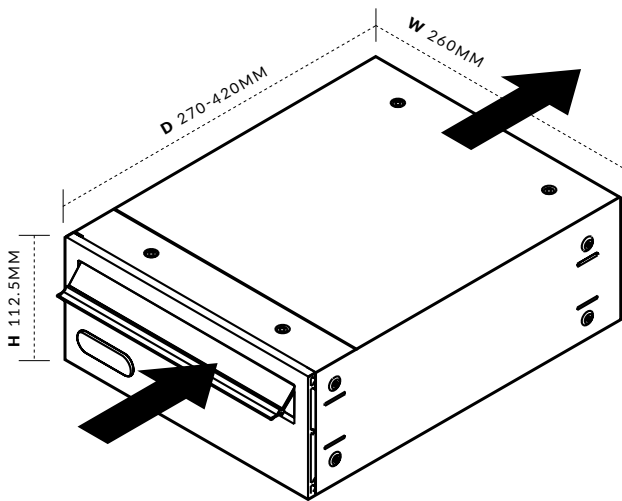

MAILBOX FEATURES:

Overview

- Dimensions (mm): 112.5H x 260W x 270 - 420D
- Aperture Size (mm): 18H x 230W
- Will accept A4 Mail

Finishes

- Zintec Steel body and Aluminium Extrusion front face
- Polyester powder coating paint
- Available in all standard RAL colours as standard
- Option to upgrade to any RAL colour for an additional fee
- Weather and vandal resistant

Installation Options

- Bankable up to 10 high, no restriction on width
- Through the Wall
- Integrates with Door Entry Systems
- Bespoke Arrangement

Applications

- Suitable for internal or external use

Compliance

- Conforms to Secured by Design Homes 2025 guidelines

Accessories/Optional Extra

- Can be engraved or fitted with Vinyl lettering
- Aperture restrictors

